

ALL DIMENSIONS IN MILLIMETRES

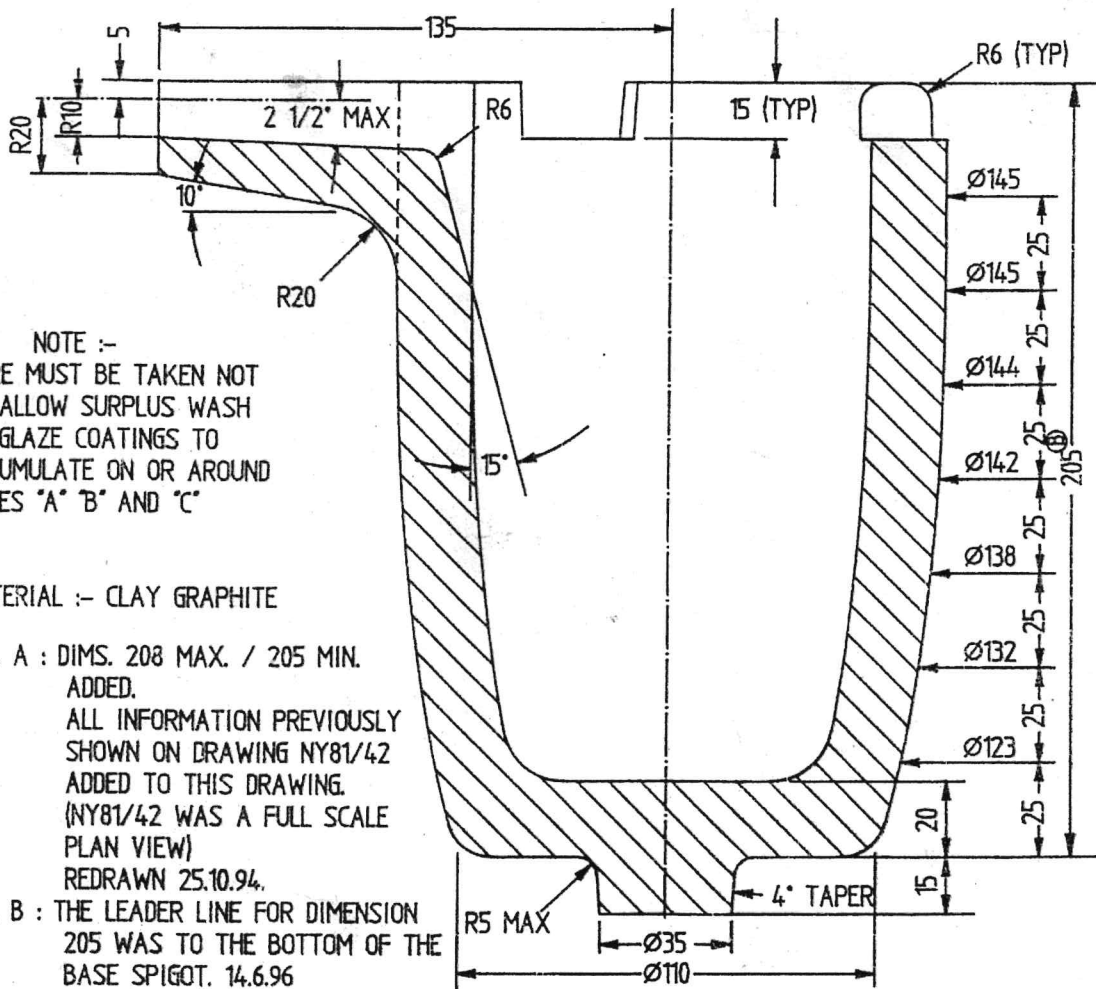
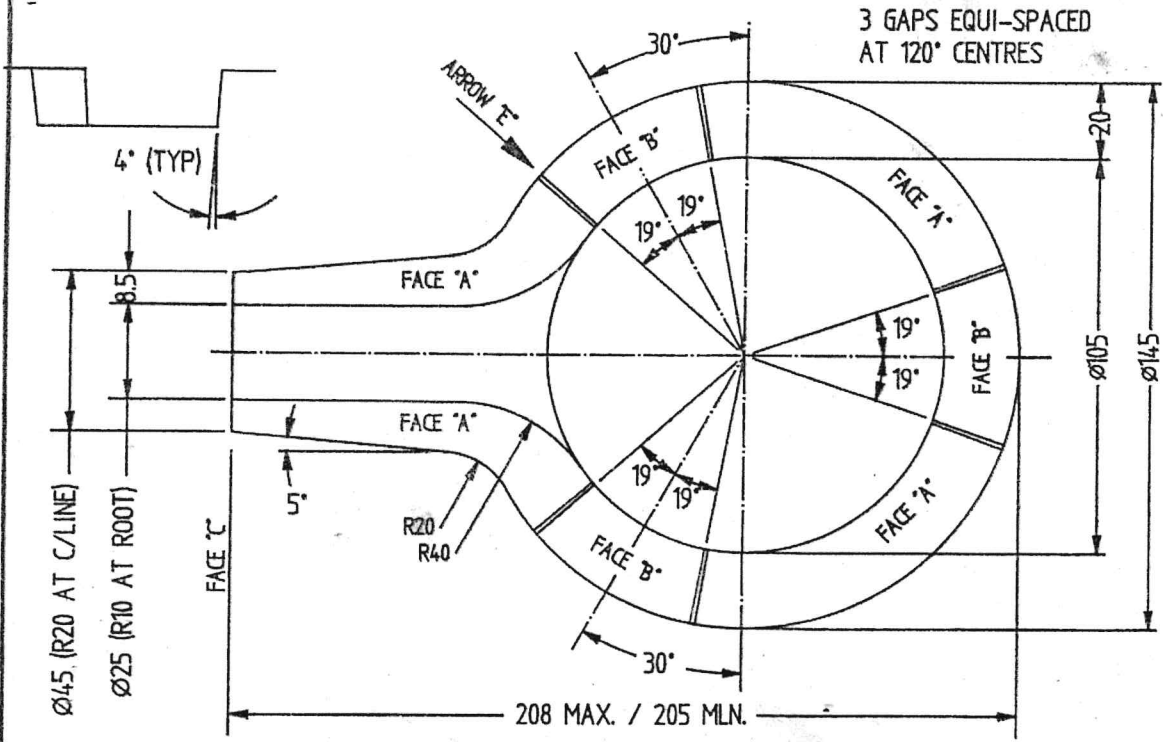

NOTE :-
CARE MUST BE TAKEN NOT TO ALLOW SURPLUS WASH OR GLAZE COATINGS TO ACCUMULATE ON OR AROUND FACES 'A' 'B' AND 'C'

MATERIAL :- CLAY GRAPHITE

REV. A : DIMS. 208 MAX. / 205 MIN. ADDED.
ALL INFORMATION PREVIOUSLY SHOWN ON DRAWING NY81/42 ADDED TO THIS DRAWING. (NY81/42 WAS A FULL SCALE PLAN VIEW)
REDRAWN 25.10.94.

REV. B : THE LEADER LINE FOR DIMENSION 205 WAS TO THE BOTTOM OF THE BASE SPIGOT. 14.6.96

ATP 10 CRUCIBLE (RHODES FLAMEFAST FURNACE)